



# Digital Transformer - Differential Protection

## DQ2S 2 and DQ3S 2 (Version 4)

### 1 Application

Both DQ2S2 and DQ3S2 are complex protection devices to be applied in the transformer and motor sector. Mainly they are used for biased transformer-differential protection:

- DQ2S 2 for two-winding transformers
- DQ3S 2 for three-winding transformers

As additional function a three-stage overcurrent-time relay, a thermal model for overload protection and various possibilities for generating output commands by binary output signals are available.

The overload protection and the overcurrent-time stages may selectively be assigned to one winding end of the transformer respectively to one outgoing feeder.

DQ2S 2 device can be connected to both 1 A and 5 A current transformers by choosing the appropriate terminals. Against it, the DQ3S 2 has different models for rated currents.

The communication with the station control system is issued according to the IEC 60870-5-103 interface standard. Operator and evaluation software for PC is available.

All devices of the D...2 series have a short restart time.

### 2 Function

The protective and additional functions indicated below may be issued in dependence of the protector design. Most of these functions may separately be switched on or off:

- short-circuit protection for transformers with in sections adjustable stabilisation, integrated vector groups and transformation ratio matching, neutral

current correction depending on treatment of the transformer neutral point

- tripping lockout at closing operations by evaluating the share of the 2<sup>nd</sup> harmonic in the differential current, cross-block function can be switched off
- tripping lockout at overexcitation by evaluating the share of the 5<sup>th</sup> harmonic in the differential current
- improved stabilisation against transformer saturation
- three-stage overcurrent-time protection in which the first stage can be IDMT or DT. The others are definite time stages (DT)
- thermal replica for the overload protection of the transformer respectively of an protective object connected at one terminal end
- Detecting and processing of binary signals like
  - Buchholz alarm and tripping
  - temperature limit monitoring and its tripping
  - different external TRIP-commands demands, e.g. tripping by keys
  - blocking signals for TRIP - commands and starting of overcurrent-time protection
  - fault recording
  - characteristic set change
- two pulse shaper stages for creating on- and off-delays with logic combination of input signals
- operate value display for phase currents or as a commissioning support for differential and holding (restrain) currents
- extensive event logging of protective and peripheral happenings and fault recording

- two characteristic sets
- free configuration of trip and signal relays and LED's
- communications protocol for operation at a station control system according to IEC 60870-5-103
- operator control in plain-text over front panel with a four-line LC display
- trip test
- optocoupler check
- optical fibre interface test
- self-monitoring: watchdog modules in the hardware and cyclic software-tests

### 3 Construction

The DQ2S 2 resp. DQ3S 2 is housed in a sheet-steel enclosure in the following designs:

- panel surface-mounting
- panel flush mounting.

Additionally three different installation positions exist – current terminals

- at the bottom
- right or
- left hand side

For all versions, the low depth of 140 mm allows the installation into medium-voltage switchgear cells. Therefore, behind the relay other devices like terminals may be located.

For panel surface mounting, the terminals can be accessed from the front panel, whereas for panel flush-mounted units they can be accessed from the rear side.

The front operator panels of all versions are equal. They include the membrane keyboard, a four-line LCD display of 20 characters per line, 12 LED's and a 9-pin Sub-D connector for plugging in a PC.

The optional IEC 60870-5-103 interface is available in two physical designs: op-

tical fibre connection or RS485 twisted-pair wire. The optical fibre interface has a connector for each of the transmission and reception directions. The alternative RS485 wire interface uses terminals. It is located in the upper level of the terminals.

#### 4 Method of operation

The processing of the measured quantities digitised by an A/D converter is issued by 16-bit microcontroller.

The setting sets are stored in an EEPROM to be preserved if the supply voltage and the back-up battery fail. Due to the back-up battery, recorded events and disturbance data are maintained in case of an auxiliary voltage failure. The restart time of the device is reduced also.

A real-time clock is provided for time stamping of events.

#### 5 Protective functions

##### 5.1 Biased differential protection

The DQ2S 2 and DQ3S 2 detect the phase currents  $i_1, i_2, i_3$  of the high voltage and low-voltage side, in addition to this, the DQ3S 2 also detects the currents of the tertiary system.

The instantaneous values of the phase currents measured in each scanning phase are worked up to differential and restrain currents in form of effective values, corresponding to defined vector groups, transformation ratios and possibly neutral current. The ratio adaptation  $k$  of the transformer windings is related to the feeding high voltage side (OS) and calculated with rated transformer voltages and rated currents of the instrument transformers

$$k_x = \frac{Vn_{Tx} \cdot In_{Wprx}}{Vn_{TrOS} \cdot In_{WprOS}}$$

The differential current acts as an operating criterion while the restrain current acts as a biasing respectively holding criterion, corresponding to the characteristic fig. 1. The influence of D.C. current is minimised.

A stabilisation against transformer saturation in case of external faults is issued by raising the characteristics gradient in two steps (time dependent).

The differential current releasing may be blocked by input signals.

##### 5.2 Inrush and overexcitation stabilising

Spurious trippings by magnetising inrush are avoided by valuating the ad-

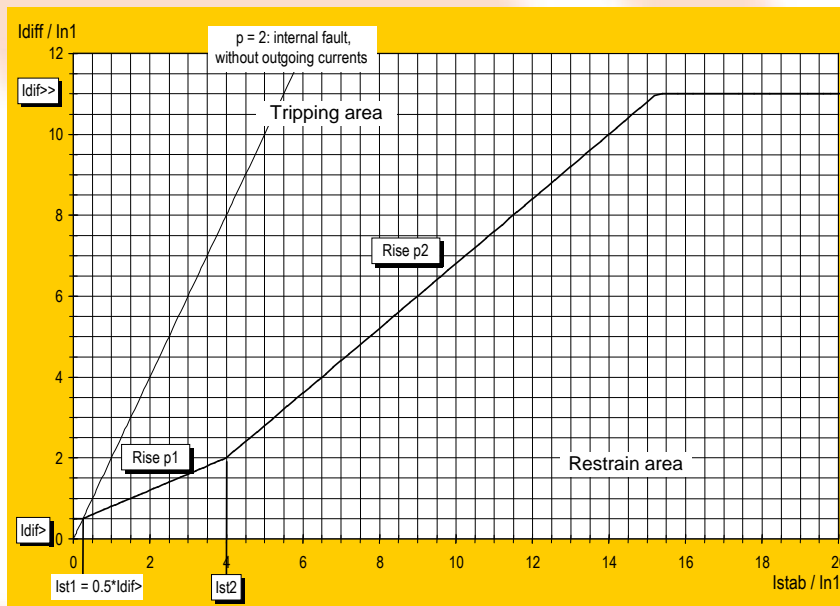

Fig. 1: Characteristics of the stabilised differential protection DQ2S2, DQ3S2

justable ratio from the 1<sup>st</sup> to the 2<sup>nd</sup> harmonic in the differential current.

The tripping at ratio overrange in a conductor, independent from the result of the other conductors, will be blocked (cross block). The cross block function may be switched off.

With greater differential currents, no tripping blocking is issued (limit adjustable).

The handling of differential currents by overexcitation is issued similarly but with the difference that instead of the 2<sup>nd</sup>, the 5<sup>th</sup> harmonic is used, and the blocking limit of the differential current is defined (2·In).

##### 5.3 Overcurrent protection (DT/IDMT)

The integrated, three-stage overcurrent-time protection has to be assigned by setting to one of the two respectively three winding ends (with restrictions it is possible to assign each stage to another winding).

In contrast to the  $I_L \gg$  und  $I_L \gg \gg$ , stages the  $I_L >$  can be set to an inverse time also. In this case the tripping time is determined using the formulas indicated below (IEC 60255-3 or BS 142).

###### 1. long time inverse:

$$t_{a \max} \geq t_a = \frac{120}{\left(\frac{I}{I >}\right) - 1} \cdot t >$$

###### 2. inverse:

$$t_{a \max} \geq t_a = \frac{0,14}{\left(\frac{I}{I >}\right)^{0,02} - 1} \cdot t >$$

###### 3. very inverse:

$$t_{a \max} \geq t_a = \frac{13,5}{\left(\frac{I}{I >}\right) - 1} \cdot t >$$

###### 4. extremely inverse:

$$t_{a \max} \geq t_a = \frac{80}{\left(\frac{I}{I >}\right)^2 - 1} \cdot t >$$

The effective values of the three phase currents will be compared with the set operate value, when a start is submitted the set tripping time will be started.

The startings of the overcurrent protection operates with an adjustable resetting ratio (useful in case of saturation) and each may be blocked.

##### 5.4 Thermal overload protection

The integrated overload protection works with a thermal model and has to be assigned to one of the two respectively three winding ends.

Using the greatest effective value of the three phase currents and the set thermal time constant, the thermal replica will be controlled continuously. The calculated thermal level will be compared with the set tripping value respectively warning level value. If occasion arises, a response or an alarm is issued.

The influence of the previous load will be regarded. The characteristic meets IEC 60255-8.

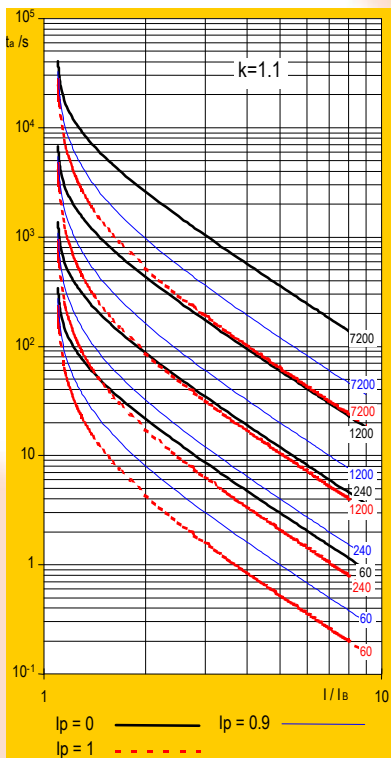

Fig. 2: Release time characteristics for various heating time constants  $\tau$  and preloading currents  $I_P$  at  $k=1.1$

$$t_a = \tau \cdot \ln \left[ \frac{\left( \frac{I}{I_B} \right)^2 - \left( \frac{I_P}{I_B} \right)^2}{\left( \frac{I}{I_B} \right)^2 - k^2} \right]$$

wherein are:

- $t_a$  tripping time after overload has been started
- $\tau$  heating time constant of the equipment
- $I$  actually flowing current
- $I_B$  basic current (nominal current of the protective object)
- $I_P$  preloading current
- $k$  factor for multiplying the basic current to reach the operating limit.

### 5.5 External TRIP commands

Over the binary optocoupler inputs a TRIP command may be demanded. Up to eight TRIP commands can be used. Configured to output relays the connected circuit breakers can switch off. Grouping all TRIPs in the protection relay gives the advantage of logging them in the event memory and in substation control equipment.

### 5.6 Processing of input signals

The input signals wanted for the different protective and additional functions are freely programmable; several inputs for one function may be used. Processing the optocoupler input signals, the logic functions negation (NOT), AND, OR are available. As a result, there are logical input signals for internal processing in the protector.

### 5.7 Pulse shaper stage

This stage is preferably used to perform the following special tasks:

- in and output coupling: activation of a selectable visual display or an output relay through an input signal which can be modified optionally in time characteristics (also latching see Fig. 3), or can be extracted from the logic operation of several input signals.
- Blocking of TRIP command
- Input and time controlled start of a disturbance data recording.

The pulse shaper stage has two ports functioning independently of each other.

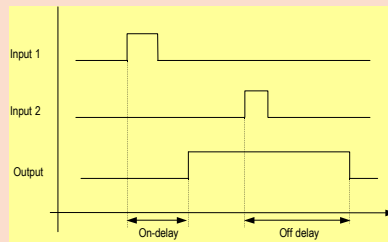

Fig. 3: Example for one effect of the pulse shaper stage

### 5.8 Change of characteristic sets

Two characteristic sets may be entered. The respectively active set can be selected by an operator action or by command from the substation control system. Changing the configuration allows to switch between the characteristic sets using the optocouplers.

### 6 Additional functions

#### 6.1 Display of operating values

As long as no trip, alarm or malfunction messages are present, the DQ2S 2 / DQ3S 2 display indicates

- the 6 or 9 phase currents or
- the total and differential currents (start-up aid).

With currents the user may chose between

- primary or secondary (related to the rated current) amounts.

When using overload protection then the measured operate currents in rotation with the thermal level is shown.

### 6.2 Visual display of system faults

For a first short information concerning a system (transformer) fault or device status, 12 light emitting diodes (LED's) and a four-line display with 20 characters each per line are available.

The LED display as delivered in the standard configuration is shown in Table 1.

As an output command can be derived practically from each sub-function of the DQxS 2, the LED assignment can be changed within wide limits by changing the configuration.

The four-line LCD text display shown after a TRIP command includes

- tripping reason, expressed by short symbols,
- period of fault (relative time until TRIP command),
- r.m.s. value of current in the individual phases at the time of the TRIP command output,

Furthermore the runtime together with the greatest phase current and the accompanying winding is named after a start of the overcurrent time protection. Information that is more detailed can be found in the event and disturbance data memories of the relay.

LED	steady light	flashing light
green G	Protection available	u
red R	Alarm	l Malfunction
yellow 0	-	TRIP
yellow 1	-	Diff-protection
yellow 2	-	-
yellow 3	-	-
yellow 4	-	-
yellow 5	-	-
yellow 6	-	-
yellow 7	-	-
yellow 8	-	-
yellow 9	-	-

Table 1: LED assignment on delivery for DQxS 2 (abbreviations are as follows: u: updating l: latching t: additional indication on LCD)



### 6.3 Event logging

Event logging is used to make a follow-up analysis of what happened in the protective object and in the protective relays.

To achieve a better survey, the events are divided into the following groups:

- system faults,
  - indications,
  - operator actions and
  - internal malfunctions and alarms.
- Moreover, it can be seen whether the events occurred during
- normal, or
  - test operation.

The division into

- main and
- subevents

supports the temporal classification.

Main events are numbered and time-stamped. Subevents contain the time in ms relative to the assigned main event. The event memory is a shift memory (holding up to more than 200 events) whose oldest events are overwritten.

The content of the event memory can be selected and displayed on the front panel without using a PC.

The installed back-up battery preserves the event memory content even if the supply voltage fails.

### 6.4 Disturbance data logging

Disturbance data logging includes the storage of

- the digital instantaneous values of all measured phase currents and
- differential and stabilising currents
- as well as time tags of significant reactions (differential start, phase current starts, TRIP command Buchholz warning and TRIP) and
- optocoupler input levels.

Logging clock is 1 ms.

Logging is activated by:

- system faults located by the protector or
- external logging signals.

The number of the available loggings is variable.

Logging duration:

- 50 ms pre-travel
- 150 ms overtravel
- max. 2 s

Several logs are possible until 6 s are reached.

The disturbance data logging caused by an input signal is always continuous during the active signal, max. 2 s.

The display of the stored incidents can only be visualised on a PC screen. The

disturbance data memory is a shift memory whose oldest data are overwritten.

The stored disturbance data can only be visualised on a PC screen using PC operating programs.

The installed back-up battery preserves the content of the disturbance data memory if the supply voltage fails.

### 6.5 Time synchronisation

Beside the default time synchronisation by a substation control system, it is possible to set the time 12:00:00 by an optocoupler input signal.

## 7 Tests

### 7.1 Self-test

Comprehensive monitoring routines of the hardware and for the software are provided to detect and signal malfunctions of the protection device. There are cyclic tests and tests during start-up.

Depending on the detected abnormal condition, the protector is taken out of operation or an alarm is issued. Using the green LED to indicate the ready state (in service) and the red LED for malfunction and alarm signal is advisable. The pre-configured signal relay "Protection available" signals any malfunction and lack of auxiliary voltage. Alarms may be configured to another signal relay.

### 7.2 C.B.-Test

To test the break circuits of the circuit breaker, a trip test may be performed. Pressing the „Tests“ key on the protection device activates this function.

### 7.3 Checking optocoupler inputs

In the "Tests", menu optocoupler test can be selected. The actual state of all inputs is shown.

### 7.4 Test of fibre optic interface

An easy to use check for transmitter, receiver and fibre optic cable is integrated.

### 7.5 Application of test plug devices

Checking the mounted protection relays periodically many power supply companies apply test plug devices or test selector switches that cause a safe switch over from the measured quantities of the system to the test devices. The TRIP command to the circuit breaker is also involved into the switch over.

Building the "check/test mode", the test plug device respectively the test selector switch has to make a binary signal for one optocoupler input of the protec-

tor available. This marks all logged events as "test". Information blocking is available to substation control equipment by an optocoupler input too.

## 8 Serial interfaces

The front 9-pole Sub-D connector constitutes the interface S0 for the operator PC.

The IEC 60870-5-103 interface S1 for connection to the substation control system is available as an option. The optical fibre variant is a point-to-point connection while the RS485 is a twisted-pair half-duplex connection (several devices may be connected).

## 9 Operation

### 9.1 Front panel

The following operations can be executed on the front panel:

- Reading and resetting of LED's and display provided automatically by the relay including the following:
  - operating value display during normal operation,
  - LCD report after a TRIP command of the protector,
  - LCD report after switching off the protector and because of an internal malfunction.
  - In case of an alarm, the operating values and the alarms are displayed.
- Setting of the protector
  - Pressing the password-protected "Setting" key displays an easily comprehensible plain-text menu comprising the following main items:
    - *Equipment adaptation* - data concerning the installation and the system,
    - *Protective functions* - switching the protective and additional functions on or off,
    - *Input configuration* - free assignment and logic combination of optocoupler input signals to device software functions.
    - *Output configuration of relays and LED's* - free assignment of the possible output commands to trip relays, signal relays and LED's, this can generate group signals,
    - *Characteristic sets* - setting values for the selected protective functions are separately adjustable for two characteristic sets,
    - *Device address*,
    - *Operator control* - common settings, e.g. protector On/Off, pass-



word, date and time, operating mode, etc.

- Display of stored information  
After pressing the "Readout" key the stored information may be indicated on the display:
  - logged events (with running time),
  - all settings,
  - information on the protector type, e.g. versions.As the key is not password-protected and the information selection is shown in a plain-text menu, it is easy to get a local readout.
- Calling of tests  
Pressing the "Tests" key accesses a menu used for the above-mentioned tests and the manufacturer's service. The menu is password-protected.

### 9.2 PC operator routine COMM-3

Although no PC software is necessary for setting and readout of the protection device a PC operator routine COMM-3 and graphic software SDA 2 is available. It is used for preparing and performing the setting of the digital protection relay at the engineer's place of work.

COMM-3 consists of a superordinated management program and different device programs, characterised by the structure version number.

In addition to setting the protectors, the program may also be used for reading out, storing and displaying events. The read disturbance data can be exported into the COMTRADE format (IEEE standard C37.1991, EN 60255-24) for using them with other COMTRADE compatible programs (e.g. test devices). Graphic display and evaluation of disturbance data can be done by the graphics software SDA 2 featuring both the COMTRADE file format and the RIO format (from company Omicron, Austria).

### 9.3 Control by substation

The IEC 60870-5-103 interface of digital protectors to the substation control equipment is optionally available. Regardless of the manufacturer, this interface supports the connection of protectors to correspondingly compatible equipment.

The scope of signals and commands agreed upon by the compatibility class 2 of a transformer differential with an overcurrent-time protection is available.



## 10 Specifications

The protection relay satisfies the requirements of the product standards EN 60255-6 (IEC 60255-6); DIN 57435, part 303; IEC 60255-8; IEC 255-13.

### Mechanical construction

- sheet-steel housing for (depending on model) for panel surface mounting or panel mounting
- dimensions see dimensioned drawings
- weight DQ2S 2: approx. 6.5 kg  
DQ3S 2: approx. 7 kg
- degree of protection (EN 60529) housing IP 51  
terminals IP 20
- terminals
- transformers solid wire 0.5 ... 16 mm<sup>2</sup>  
stranded wire 0.5 ... 10 mm<sup>2</sup>
- others: solid wire 0.2 ... 4 mm<sup>2</sup>  
stranded wire 0.2 ... 2.5 mm<sup>2</sup>

### Permissible ambient conditions

- operating temperature -10°C...+55°C
- storage temperature -25°C...+55°C
- transport temperature -25°C...+70°C
- humidity rating, yearly mean value <75% for 30 days 95% at <40°C  
moisture condensation not permitted

### Mechanical strength

- resistance to earthquakes (IEC 255-21-3) nominal frequency range 1...35 Hz  
cut-off frequency 8...9 Hz  
horizontal 3.5 mm; 10 m/s<sup>2</sup>  
vertical 1.5 mm; 5 m/s<sup>2</sup>
- vibration strain (IEC 255-21-1, IEC 68-2-6) Fc: 10...150 Hz; 0.075 mm; 1g
- repeated impact strain (IEC 255-21-2) Ea: 11 ms; 15 g  
Eb: 16 ms; 10 g

### Auxiliary power supply

- U<sub>H</sub> depending on design 24-65.5 V DC or 60-137 V DC, 60-100 V AC or 110-320 V DC, 100-240 V AC
- operating range 0.8-1.1·U<sub>H</sub> for 24-65.5 V - version: 0.84-1.1·U<sub>H</sub>
- power consumption <15 W
- stored energy time in case of auxiliary power failure, based on nominal voltage ≥ 50 ms
- backup battery for RTC, event and disturbance data 3 V CR ½ AA lithium

### Measuring input circuits

- rated frequency 50 Hz
- rated current (I<sub>n</sub>) DQ2S2: different terminals 1/5 A  
DQ3S2: design dependent 1 or 5 A
- load capability: permanent 4·I<sub>n</sub>  
1 sec 100·I<sub>n</sub>  
limiting dynamic value (10 ms) 250·I<sub>n</sub>  
power consumption at I<sub>n</sub> <0.25 VA

### Binary signal inputs (optocoupler) <sup>1</sup>

<sup>1</sup> On special-wish, differently from the default long-range input voltage optocoupler

- nominal input voltage (V<sub>i</sub>) 24...220 V DC
- power consumption <4·10<sup>-4</sup> (V<sub>i</sub>)<sup>2</sup> W
- logic low level <10 V

### Output relays

- trip relays (marked S1...S4) having two make contacts each 4  
switching voltage 300 V DC, 250 V AC  
limiting making capacity 2000 W (VA)  
limiting breaking capacity 90...250 W (voltage- and load dependent)  
0.25 A at 220 V DC, L/R = 0 ms  
0.15 A at 220 V DC, L/R = 40 ms
- both contacts in series: 0.25 A at 220 V DC, L/R = 40 ms  
limiting continuous current 8 A  
limiting short-time current for 0.5 s 30 A
- signal relays (marked M1...M8) having switching voltage 300 V DC, 250 V AC  
switching current 8 A  
switching capacity <2000 VA,  
50...220 W (voltage- and load dependent)  
limiting continuous current 6 A

### Serial interfaces

- PC interface RS 232  
front panel 9-pin Sub-D connector  
electrical isolation (depending on design) 0 kV / 1.5 kV
- IEC 60870-5-103 interface optional  
optical fibre connector F-SMA  
optical wavelength 850 nm  
distance < 1 km  
permissible path attenuation < 8 dB  
glass fibre 62.5/125 µm  
idle position light on  
or RS 485 half-duplex  
unit load 1  
potential separation 2 kV, 1 s  
connection terminal

### Displays

- LED's green: 1; red: 1; yellow: 10  
states steady light, flashing, off
- LC display four-line display of 20 alphanumeric characters each illuminated

### Setting values and ranges (selection)

- number of switchable characteristic sets 2
- object adaptation: transformer rated voltage 0.4...400 kV  
primary CT rated currents 0.01...20 kA  
vector groups 0...11
- possible ratio adaptation k 0.4...3.0
- stabilised differential protection (fig. 1) start of characteristic I<sub>dif</sub>> 0.10...0.50·I<sub>nOS</sub>  
biasing factor p1 0.20...1.00  
base point I<sub>st2</sub> 0.50...4.00·I<sub>nOS</sub>  
biasing factor p2 0.20...1.00  
end of stabilisation I<sub>dif</sub>>> 5...20·I<sub>nOS</sub>  
tripping times t<sub>dif</sub>, t<sub>dif</sub>>> 0.00...9.99 s
- inrush stabilisation I<sub>100Hz</sub> / I<sub>50Hz</sub>> 0.10...0.40  
end of stabilisation 2.0...10.0·I<sub>nOS</sub>

inputs can be dimensioned for a Low/High switching voltage of about 60 V.

- overexcitation stabilisation I<sub>250Hz</sub> / I<sub>50Hz</sub>> 0.10...0.45
- overcurrent-time protection operate value I<sub>L</sub>> (DT) 0.20...25.0·I<sub>n</sub>  
I<sub>L</sub>> (IDMT) 0.20...4.0·I<sub>n</sub>  
I<sub>L</sub>>> (DT) 0.20...25.0·I<sub>n</sub>  
I<sub>L</sub>>>> (DT) 0.20...25.0·I<sub>n</sub>  
resetting ratio 0.2...0.95  
tripping time t<sub>L</sub>>, t<sub>L</sub>>> 0.00...65.00 s  
t<sub>L</sub>>>> 0.00...9.99 s  
time factor for IDMT 0.05...2 s
- thermal replica (overload protection) basic current I<sub>B</sub> 0.2...2.0·I<sub>n</sub>  
operate factor k 1.00...1.2  
thermal time constant 60...7200 s
- warning levels 40.0...100.0 %
- pulse shaper stage on delay, off delay 0.00...9.99 s

### Tripping times

- I<sub>dif</sub> > 1,5·I<sub>dif</sub>>> typ. 25 ms
- I<sub>dif</sub> > 5·I<sub>dif</sub>>> typ. 19 ms

### Routine testing

- dielectric test 2.5 kV, 50 Hz, 1 s  
exceptions: power supply 2.83 kV DC  
RS485 1.6 kV, 1 s
- Each protection relay will be subjected to a 72-hour alternate temperature test while in function.

### Type testing

- impulse voltage test 5 kV; 1.2/50 µs; 500 Ω
- dielectric test 2.5 kV, 50 Hz, 60 sec  
exceptions: power supply 2.83 kV DC  
RS485 1.5 kV, 60 s  
Isolated PC interface S0 1.5 kV, 60 s
- EMC noise immunity EN 50082-2, severity class 3  
electromagnetic RF field  
magnetic field of power engineering frequency  
discharge of static electricity (ESD)  
fast transients (bursts)  
surges  
RF interference test (IEC 255-22-1)  
transformer cross voltage 2.5 kV
- EMC emitted interference EN 50081-2



## Order data DQ2S 2/DQ3S 2

Pl.-No.: 1743

Type of device: 5<sup>th</sup> digit  
 for 2 windings: DQ2S2 3  
 for 3 windings: DQ3S2 4

Rated current: 6<sup>th</sup> digit  
 DQ2S2 1/5A 0

DQ3S2	W1	W2	W3	
	1A	1A	1A	1
	1A	1A	5A	2
	1A	5A	5A	3
	5A	5A	5A	5

Auxiliary voltage: 7<sup>th</sup> digit <sup>2</sup>  
 110 - 240 V DC/AC 0  
 60 - 137 V DC 1  
 24 - 65 V DC 2

Type of housing: 8<sup>th</sup> digit  
 panel surface-mounted  
 CT terminals down 0  
 CT terminals right 2  
 CT terminals left 4  
 panel flush-mounted  
 CT terminals down 1  
 CT terminals right 3  
 CT terminals left 5

IEC interface / language: 9<sup>th</sup> digit  
 Fibre optical / German 0  
 Fibre optical / English 1  
 RS485 / German 5  
 RS485 / English 6

design: 10<sup>th</sup> digit 0

Design	0	1
Optocoupler inputs	6	9
Trip relays	4	4
Signal relays with 1 CO contact	2	2
Signal relays with 1 NC contact	1	1
Signal relays with 1 NO contact	3	5
PC interf. potentially separated	X	X
IEC 60870-5-103 interface	-	X

## Optocoupler inputs:

On special-wish, differently from the default long-range input voltage optocoupler inputs can be delivered with a Low/High switching voltage of about 60 V.

This wish is separated with order to declare.

<sup>1</sup> complete voltage ranges see technical specifications

## Accessories

PC-protector interconnecting cable  
 Pl. No.: 1743 900 010

## COMM-3 PC operator software

## • Management program

Pl.-No.: 1744 990 00-

Variant: 10<sup>th</sup> digit  
 Full-version 0  
 Upgrade from COMM-2 to 3 1  
 Update of COMM-3 2  
 Demo version 9

On supplied CDROM the user manual exists as a PDF-file.

## • Device programs

Pl.-No.: 1744 991

Type of device: 8<sup>th</sup> and 9<sup>th</sup> digit  
 all devices [structure versions] 00  
 DM 2 [1004] 10  
 DSRZ(W) 2 [2001] 20  
 DSZ(W) 2 [3007] 30  
 DSZW 4 [3105] 31  
 DSZ 4 [3205] 32  
 DQ2S 2, DQ3S 2 [4008] 40  
 DD 2 [5033] 50  
 P9x-DD.. 6 [5601] 56  
 DDS(E) 2 [6002] 60  
 DSRZE 2 [7000] 70  
 P9x-DS.. 6 [7604] 76

Variant: 10<sup>th</sup> digit  
 current structure version 0  
 old structure version 1

When reordering a device program the structure version number of the device is necessary additionally (see label on device).  
 Example for DSZ 2, old structure version 3001:

Pl.-No. 1744 991 **301- 3001**

## SDA 2 graphics software

Pl.-No.: 1744 992 000

On supplied CDROM the user manual exists as a PDF-file.

## User manual COMM-3, SDA 2 printed version

Pl.-No.: 1744 993 0-

Language: 9<sup>th</sup> digit  
 German 0  
 English 1

Manual: 10<sup>th</sup> digit  
 COMM-3 0  
 SDA 2 1

Sprecher Automation  
 Deutschland GmbH

Moellendorffstr. 47  
 10367 Berlin  
 Germany  
 Tel: +49 30 6449241-70  
 Fax: +49 30 6449241-99

Email: [info@sprecher-automation.com](mailto:info@sprecher-automation.com)

Internet: [www.sprecher-automation.de](http://www.sprecher-automation.de), [www.sprecher-automation.at](http://www.sprecher-automation.at), [www.sprecher-automation.com](http://www.sprecher-automation.com), [www.sprecher-automation.pl](http://www.sprecher-automation.pl), [www.sprecher-automation.sk](http://www.sprecher-automation.sk)

Sprecher Automation GmbH

Franckstrasse 51  
 4018 Linz  
 Austria  
 Tel: +43 732 6908-0  
 Fax: +43 732 6908-321

Sprecher Automation GmbH

Ignaz-Koeck-Straße 10  
 1210 Wien  
 Austria  
 Tel: +43 732 6908-601  
 Fax: +43 732 6908-5601

Sprecher Automation

Polska Sp z o.o.  
 ul. Łączna 4  
 58-100 Świdnica  
 Poland  
 Tel: +48 74 85135-31  
 Fax: +48 74 85135-32

Sprecher Automation  
 spol. s r.o.

Kopčianska 14  
 851-01 Bratislava  
 Slovakia  
 Tel: +421 2 682055-00  
 Fax: +421 2 682055-10

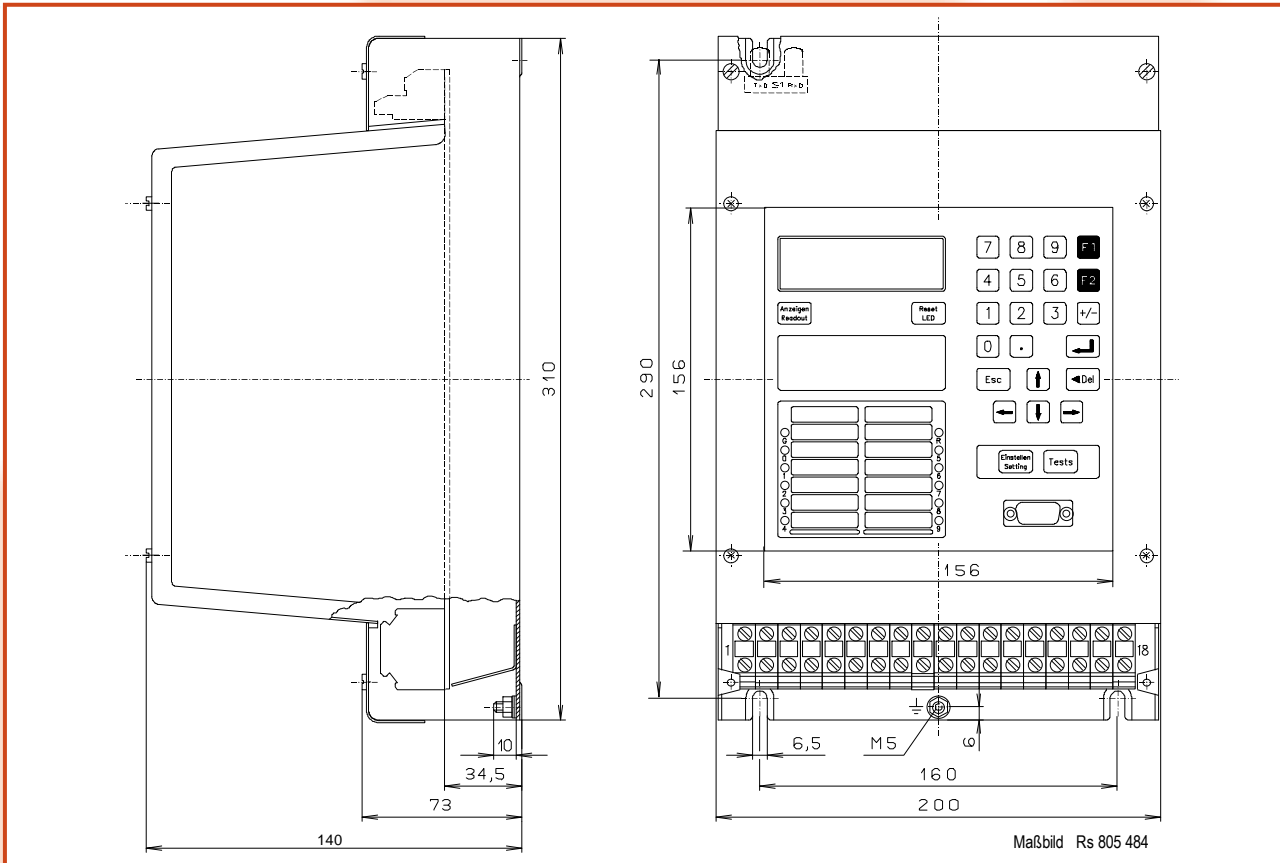

Fig. 4: Series D...2 housing for panel surface mounting, lower terminal cover not shown in top view. With the horizontal models the keypad is turned + or -90°.

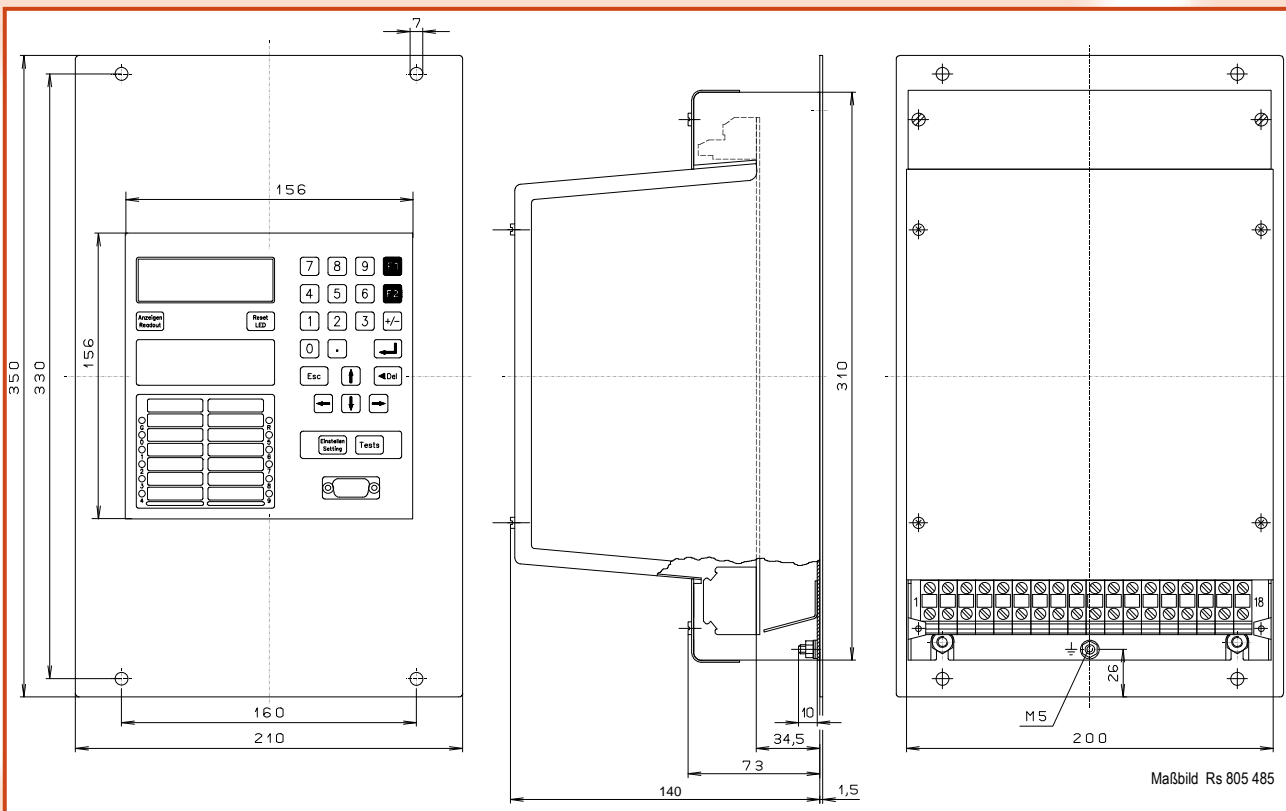
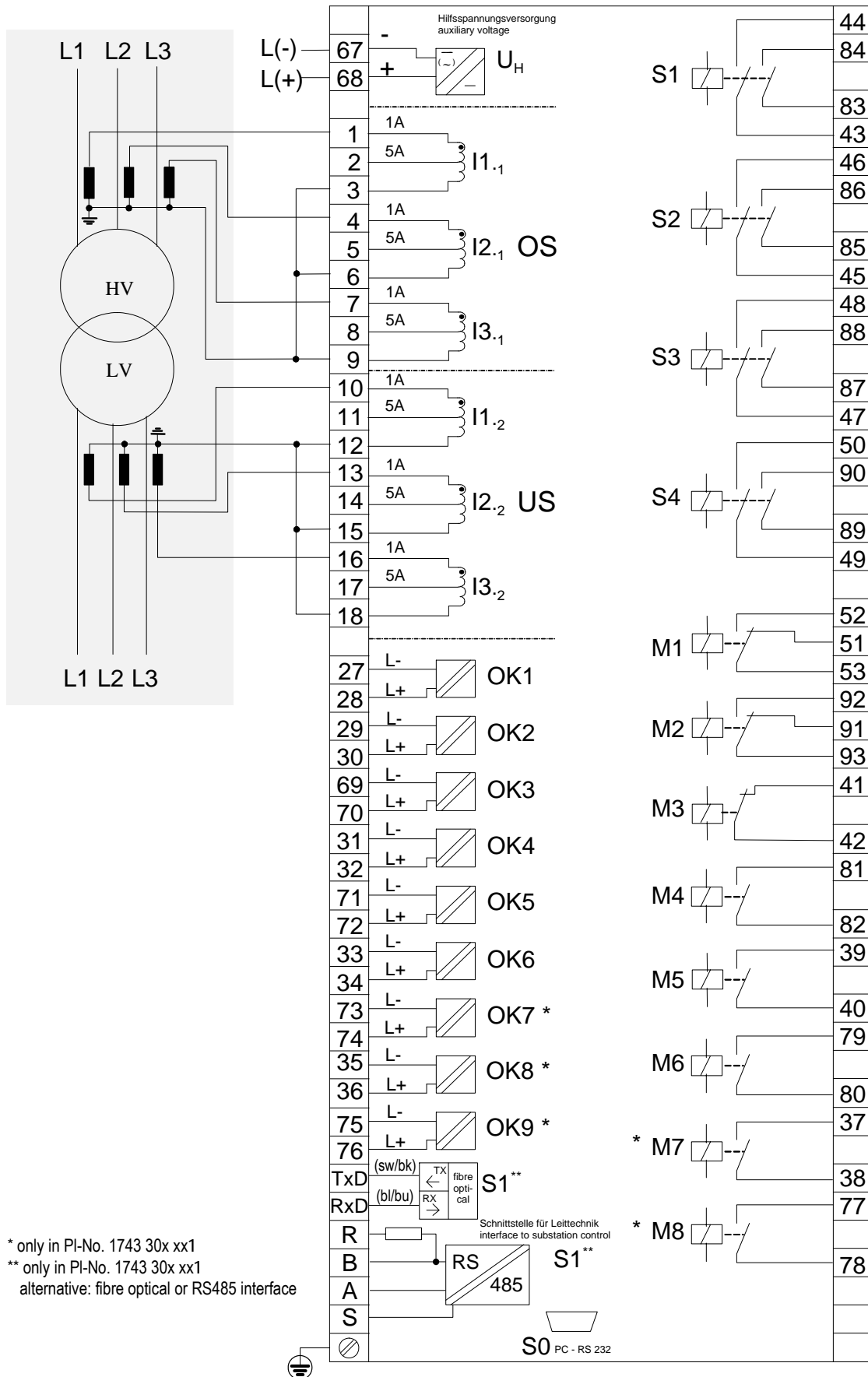

Fig. 5: Series D...2 housing for flush panel mounting, lower terminal cover not shown in rear view (right-hand side). The panel cut-out should be 202 mm x 312 mm when device will be put through from front side. With the horizontal models the keypad is turned + or -90°.



Hardware Version 2.x



\* only in PI-No. 1743 30x xx1  
 \*\* only in PI-No. 1743 30x xx1  
 alternative: fibre optical or RS485 interface

Fig. 6: Terminal assignment of DQ2S 2

