



# Digital Directional Overcurrent-Time Protection, Self-Powered DSRZW 2

## 1 Application

This multifunction protection device is used mainly for directional overcurrent-time protection of single and double fed lines in radial and ring systems. The system neutral may be insulated, compensated or earthed.

Additionally, it features the detection of zero-power directions in earthed-neutral systems having a possible high zero phase-sequence impedance (e.g., resistive-earthing systems, earthed overhead lines without earth wire). In this case, detecting the zero-power direction will also be possible when an automatic short-time low-resistance neutral earthing unit is available.

It can protect ties and is used as a back-up protection for transformers and generators.

In isolated-neutral or compensated systems, the protector detects the phase that has an earth-fault.

Tripping times can be reduced by utilising the signal transmission (teleprotection) between protectors. This also allows protection of short lines (instead of using a differential protection device).

Due to its transformer-fed power supply, it is especially suitable for use in batteryless stations and as a backup protector.

The readout of the LED's for a reasonable time is possible although the protection device is not supplied.

A capacitor release KA 4 is separately available for supplying the release coil of the circuit breaker. A tripping transformer can be connected if it meets the contact ratings of the DSRZW 2 - trip relay.

Some of the additional protective functions indicated below require the use of input signals or external circuits of out-

put relay contacts. The necessary auxiliary voltages for these should be provided (e.g. by employing a KA 4).

## 2 Functions

The protector integrates the protective and additional functions indicated below. Most of these functions may be switched on or off:

- definite-time phase-selective overcurrent protection (OTP)  $I_{L>}$ ,  $t_{IL>}$  and  $I_{L>>}$ ,  $t_{IL>>}$
- definite-time earth-fault current protection  $I_{E>}$ ,  $t_{IE>}$
- inverse-time phase-selective overcurrent protection, normally, very or extremely inverse for  $I_{L>}$ ,  $t_{>}$  and  $I_{L>>}$ ,  $t_{>>}$
- inverse-time earth-fault current protection  $I_{E>}$ ,  $t_{E>}$ , adjustable to very inverse or long-time inverse
- earth-fault current stabilisation
- detection of short-circuit direction
- voltage memory for three-phase short-line faults
- detection of zero-power direction
- separate time stages for forward and reverse direction
- phase-selective earth-fault detection
- switch-on-to-fault protection
- emergency overcurrent-time protection
- circuit-breaker failure protection
- auto-reclosing
- teleprotection:
  - two-wire connection to remote station
  - reverse interlock
  - intertripping
- fault localisation
- logical combination of input signals
- pulse shaper stage with
  - input and output coupling

– possible blocking of most functions by an input signal

- two characteristic sets, switchable
- operate value display
- event logging
- disturbance data logging
- trip test
- measured-value checking
- self-test
- serial Interface RS 232
- readout and setting is menu driven so the use of the PC operator software is not forced.
- short restart time after interruption of auxiliary voltage.
- LED indications without supply for a time

Options:

- PC operator routine COMM-3
- graphical representation of disturbance data SDA 2

## 3 Construction

The DSRZW 2 is housed in a sheet-steel enclosure in the following designs:

- panel surface-mounting
- panel flush mounting.

Additionally three different installation positions exist – current terminals

- at the bottom
- right or
- left hand side

For all versions, the low depth of 170 mm allows the installation into medium-voltage switchgear cells. Therefore, behind the relay other devices like terminals may be located.

For panel surface mounting, the terminals can be accessed from the front panel, whereas for panel flush-mounted units they can be accessed from the rear side.



The front operator panels of all versions are equal. They include the membrane keyboard, a four-line LCD display of 20 characters per line, 12 LED's and a 9-pin Sub-D connector for plugging in a PC.

Lettering stripes for LED's, created using e.g. Microsoft Word, are inserted near the LED's.

#### 4 Method of operation

For connecting the DSRZW 2, the phase currents  $I_1, I_2, I_3$ , and the voltages  $U_{1E}, U_{2E}$ , and  $U_{3E}$  of the system to be monitored are required.

A microcontroller with a built-in A/D converter processes all information.

The setting sets are stored in an EEPROM to be preserved if the supply voltage and the back-up battery fail.

Due to the back-up battery, recorded events and disturbance data are maintained in case of a voltage failure. The restart time of the protection device is reduced also.

Without auxiliary voltage, the status of LED's can be shown for a while.

A real-time clock is provided for time stamping of events.

#### 5 Auxiliary voltage supply

Auxiliary voltage supply is from the installation transformers in the current path with a separate transformer not used for measuring purposes being provided in the  $I_E$  path to guarantee the protectors supply even if  $I_E$  values are small.

We recommend the additional connection to voltage transformers ( $U_{LL}$ ) or to a 230 V AC supply that, however, is not mandatory. Some protective functions work at low operating currents that may not yet be sufficient for supplying the protector. Providing this additional voltage supply, setting the protection relay, reading the LCD text information and the LED indications will be possible at any time regardless of the current amount.

The auxiliary voltage supply is designed for establishing quick protector readiness following application of the transformer values and for supply starting from small current transformer currents.

#### 6 Protective functions

##### 6.1 Overcurrent-time protector (OTP)

The overcurrent-time protector may be adjusted separately for the overcurrent ( $I_{L>}$ ) and high-current ( $I_{L>>}$ ) time stages. Current measurement is phase-

selective in each phase. Users may choose between definite-time and inverse-time overcurrent protection.

Inverse-time overcurrent protection:

The tripping time is determined using the formulas indicated below (IEC 255-3 or BS 142). The following equations apply similarly to the  $I_{L>>}$  time stage.

1. inverse:

$$t_{a\max} \geq t_a = \frac{0,14}{\left(\frac{I}{I_{L>}}\right)^{0,02}} \cdot t >$$

2. very inverse:

$$t_{a\max} \geq t_a = \frac{13,5}{\left(\frac{I}{I_{L>}}\right) - 1} \cdot t >$$

3. extremely inverse:

$$t_{a\max} \geq t_a = \frac{80}{\left(\frac{I}{I_{L>}}\right)^2 - 1} \cdot t >$$

wherein are:

- $t_a$  tripping time
- $t_{a\max}$  maximum tripping time (setting value)
- $t >$   $t >_{fw}$  or  $t >_{rv}$ , time factor for forward and for reverse direction)
- $I$  measured current
- $I_{L>}$  current setting value

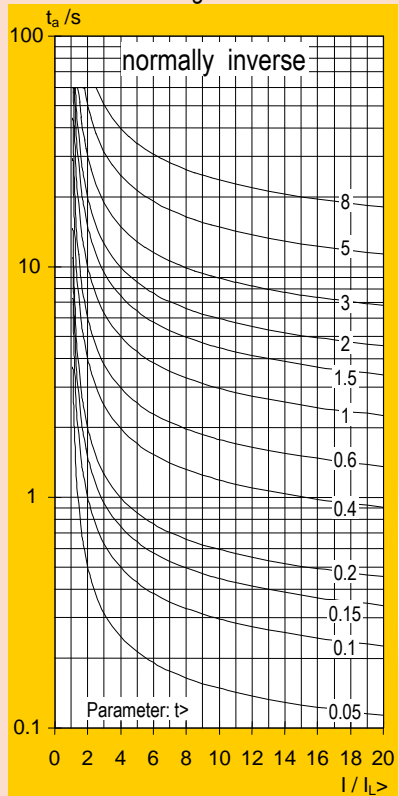

Fig. 1 Characteristics for "inverse"

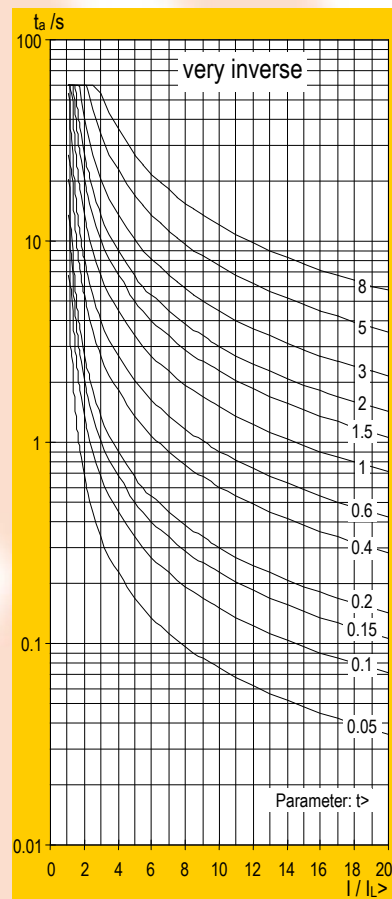

Fig. 2 Characteristics for "very inverse"

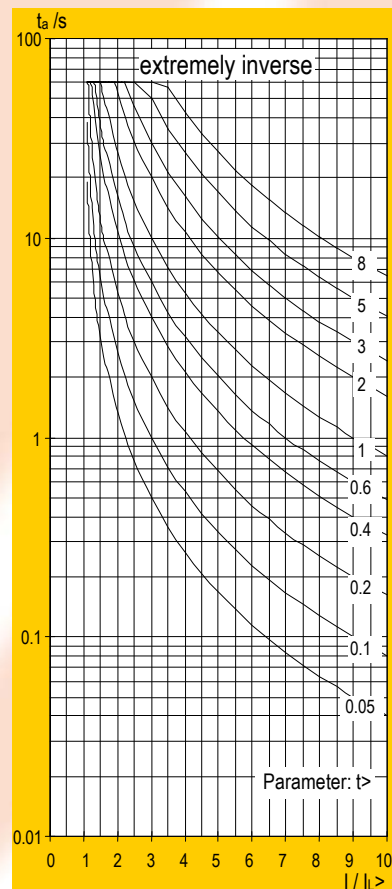

Fig. 3 Characteristics "extremely inverse"

### 6.2 Earth-fault current-time protection (short-circuit protection)

Earth-fault current-time protection uses the calculated quantity  $I_E$ .

To avoid spurious starts of the earth-fault current-time protector  $I_{E>}$ , for example due to transformer errors, the operate value is stabilised. Stabilising the earth-fault current serves to rise the operate value of the earth-fault current-time protector depending on the amount of the greatest phase current. It is effective only after a phase starting (Fig. 4). Other programmable dependencies for enabling the earth-fault current-time stage are integrated into the protector. Users of the DSRZW 2 may choose between definite-time overcurrent protection not depending on the current amount and inverse-time overcurrent protection depending on the current amount.

In addition to the "very inverse" characteristic mentioned before, the characteristic „long time inverse“ is available, also with different time stages for short circuit directions (Fig. 5):

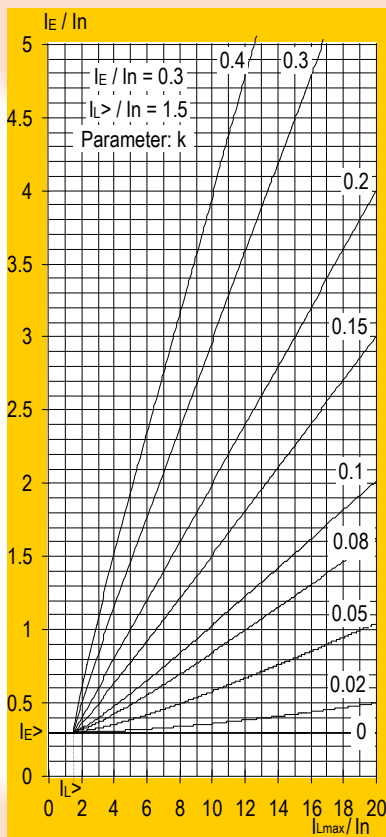

Fig. 4 Characteristic of earth-fault current stabilisation:  $I_E = f(k, I_{Lmax})$  at  $I_E/In=0.3$  and  $I_{L>}/In=1.5$

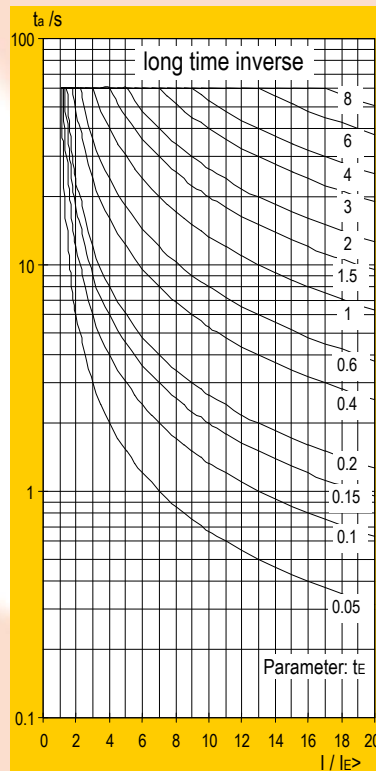

Fig. 5 Characteristics for "long time inverse"

$$t_{a\max} \geq t_{aE} = \frac{120}{\left(\frac{I}{I_{E>}}\right) - 1} \cdot t_E$$

wherein are:

$t_{aE}$ : tripping time

$t_{a\max}$ : maximum tripping time (setting value)

$t_E$ :  $t_{Efw}$  or  $t_{ErV}$ , time factor

$I$ : measured current

$I_{E>}$ : current setting value

### 6.3 Short-circuit direction

A single-element measuring method is used to determine the direction of a short circuit ("forward" corresponds to the energy flow away from the busbar). The measured values applied are selected depending on the fault - the voltage perpendicular to the fault current: 90° circuitry. Thus, except for the three-phase short-line fault, a sound measuring voltage is available for determining the direction.

In the event of a three-phase short-line fault, a voltage memory is used.

The trip command may be issued either only in forward direction or, alternatively, in both directions but with times adjustable to different values.

### 6.4 Zero-power direction

In earthed-neutral systems having a possible high zero phase-sequence impedance and when using an automatic short-time low-resistance neutral earth-

ing unit in isolated-neutral and compensated systems, the zero-power direction can be determined when the earth-fault current stage starts alone. As measured values, the values  $I_E$  and  $U_{NE}$  are used. Both values are calculated and the power is determined.

The location of the directional line may be changed by turning the interior angle (see Fig. 6). When doing so, the interior angle is perpendicular to the directional line.

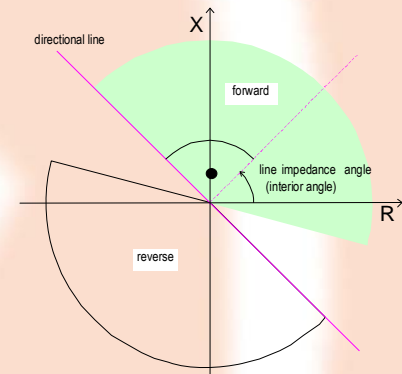

Fig. 6: Characteristic for determining the short-circuit directions

### 6.5 Selective earth-fault detection \*)

In isolated-neutral and compensated systems, earth faults can be detected.

Earth-fault detection is phase-selective, i.e., the phase affected by the earth fault is specified. A single phase-to-earth fault is signalled if a displacement voltage is present and if the voltage to earth is raised in two phases at the same time.

### 6.6 Switch-on-to-fault protection

When switching on to an existing short circuit, this function can produce an undelayed TRIP command. The input-signal "CB manual close" starts a timer. Short circuits detected during this time are switched off immediately if selected. A possibly switched on auto-reclosing function will be blocked.

### 6.7 Emergency overcurrent-time protection

If the voltage for the determination of direction fails, e.g., if the voltage transformer circuit breaker operates, the DSRZW 2 functions automatically as a non-directional overcurrent-time protector. Depending on the current stage setting, the protector works with the times for the forward direction as definite-time overcurrent protector or inverse-time overcurrent protector.

\*) DSRZW 2 has to be supplied

Also, in case of switching off direction decision the overcurrent time protection still works.

### 6.8 Auto-reclosing (ARU)

The DSRZW 2 is equipped with a three-phase auto-recloser. Up to five reclosures are possible with the first interruption being adjustable as a short-time interruption. As any other function, the auto-recloser may be switched off if unused. It may also be blocked temporarily by an input signal. Other input signals required for the auto-recloser are the ready signal from the circuit breaker and the manual close signal. Various starting conditions for the auto-recloser may be set in the protector. The auto-recloser may also be started by an external signal through an input. When looped through a break contact of the DSRZW 2, the "breaker tripped" signal may be interrupted in case the trip command is not final.

### 6.9 Teleprotection

Two signal transmission versions are available:

1. two-wire connection to remote station (another DSRZ 2 protector)
2. reverse interlock

#### Two-wire connection to remote station:

The method of operation of the two-wire connection is adjustable. A transmission relay and an optocoupler input will be required in any case.

The two-wire connection function allows rapid tripping on both sides to be made if a fault occurs in the protected line section between two protectors.

The signal loop is normally closed. Any longer interruption is reported as a fault in teleprotection. Upon each starting the transmission relay opens the contact circuit.

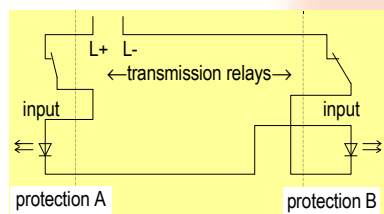

Fig. 7: Two-wire connection circuit to remote station

The signal loop is reclosed by the transmission relay when

1. the unit has responded and the signal condition set in the DSRZW 2 occurs, or
2. the starting goes.

Reclosing of the loop within an action time and during an existing start causes a trip command.

Using a separate setting, the trip command may be issued even if the interruption duration of the loop is shorter than the action time, but no start is present. This setting will be selected if faults are possible at the DSRZW 2 location that does not result in a start.

#### Reverse interlock:

Using an optocoupler input, the DSRZW 2 may be controlled so that it functions as a rapid busbar protector. Protector response must be within a higher grading time than that of the outgoing feeder protectors if a fault occurs on an outgoing feeder. On the other hand, the protector must trip within a shortest possible time if a fault occurs in busbar area.

If during a starting within the action time started simultaneously no response (start) signal is supplied from a protector in the outgoing feeders, the trip command is issued. A response signal from an outgoing feeder protector to the teleprotection input of the DSRZW 2 causes a trip within the grading time.

### 6.10 Circuit-breaker failure protection

Two effects are available:

1. detection of failure of the own associated circuit breaker
2. trip request by an input signal resulting from an external circuit breaker failure

In the former case, the time stage  $t_{CBF}$  is started together with the trip command, and during its operating time the current in all phases must have fallen below the minimum value. Otherwise an output relay to be configured will be started.

In the latter case, additional conditions for outputting the trip command may be set. For example, a phase start or another input signal may be required.

### 6.11 Input signal processing

The input signals wanted for the different protective and additional functions are freely programmable; several inputs for one function may be used.

Processing the optocoupler input signals, the logic functions negation (NOT), AND, OR are available. As a result, there are logical input signals for internal processing in the protector.

#### Pulse shaper stage

The pulse shaper stages offer the possibility of changing up to two input signals in their time characteristic. So, delays, extensions, shortenings, displacements and storage may be realised.

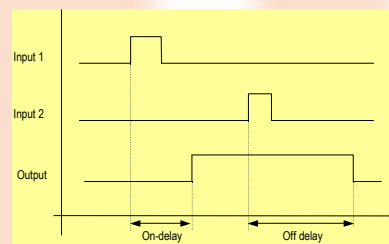

Fig. 8: Example for one effect of the pulse shaper stage

These result signals may be either

- routed to an output signal (input / output coupling) or
- may be used as a blocking signal for protective functions.
- disturbance data recording.

The pulse shaper stage has two ports functioning independently of each other.

### 6.12 Change of characteristic sets

Two characteristic sets may be entered. The respectively active set can be selected by an operator action. Changing the configuration allows to switch between the characteristic sets using the optocouplers.

## 7 Additional functions

### 7.1 Display of operating values

As long as no trip, alarm or malfunction messages are present, the DSRZW 2 display indicates measured operate values. One of the following may be selected:

- Active, reactive and apparent power
- currents and phase-to-earth voltages
- currents and phase-to-phase voltages

Primary or secondary values (referred to rated values) may be displayed.

### 7.2 Visual display of system faults

For a first short information concerning a system fault or device status, 12 light emitting diodes (LED's) and a four-line display with 20 characters each per line are available.

The LED display as delivered in the standard configuration is shown in Table 1.

All LED's can be freely assigned. Except for the upper two, the LED's are yellow. The LED "G" is green while the LED "R" is red. Furthermore, they have three possible states:



- off
- steadily on
- flashing

This provides a large variety of optical signals. As an output command can be derived practically from each sub-function of the DSRZW 2, the LED assignment can be changed within wide limits by changing the configuration.

The use of the "Readout"-key shows the LED's last state (capacitor powered) if the DSRZW 2 is not supplied with energy.

This key is not password-protected.

In case of an alarm, a DSRZW 2 malfunction or a trip a short report will be displayed. The four-line LCD text display shown after a "final TRIP" command includes the following information:

- tripping reason,
- period of fault (operating time until TRIP command),
- r.m.s. value of current in the individual phases and earth at the time of the TRIP command output,

It should be considered that this LCD report is only used as first information after a "final TRIP". Information that is more detailed can be found in the event and disturbance data memories of all relays started.

Table 1: LED assignment on delivery for DSRZW 2 (abbreviations are as follows: u: updating l: latching t: additional indication on LCD)

### 7.3 Event logging

Event logging is used to make a follow-up analysis of what happened in the protective object and in the protective relays.

To achieve a better survey, the events are divided into the following groups:

- system faults,
- indications,
- operator actions and
- internal malfunctions and alarms.

Moreover, it can be seen whether the events occurred during

- normal, or
- test operation.

The division into

- main and
- subevents

supports the temporal classification.

Main events are numbered and time-stamped. Subevents contain the time in ms relative to the assigned main event.

The event memory is a shift memory whose oldest events are overwritten.

The content of the event memory can be selected and displayed on the front panel without using a PC.

The installed back-up battery preserves the event memory content even if the supply voltage fails.

### 7.4 Disturbance data logging

Disturbance data logging means the storage of the digitised instantaneous values of measured input quantities together with the time marks of some important events (like start, trip and optocoupler inputs). Logging clock is 1 ms. Logging is activated by:

- system faults located by the protector or
- external logging signals

For logging the power system failures, there are two possibilities:

1. Continuous logging from "coming" to "going" of the general start with a 50ms pre-travel, where the maximum logging duration for a fault is 4 s,
2. event controlled logging with 50 ms pre-travel and 150 ms overtravel.

The controlling events are:

- starting comes,
- starting goes,
- starting changes,

LED	steady light		flashing light	
green G	Protection available	u	–	
red R	Alarm	l t	Malfunction	l t
yellow 0	TRIP	l t	–	
yellow 1	I1>>	l	I1>>	l
yellow 2	I2>	l	I2>>	l
yellow 3	I3>	l	I3>>	l
yellow 4	IE>	l	–	
yellow 5	Earth-Fault L1	l	–	
yellow 6	Earth-Fault L2	l	–	
yellow 7	Earth-Fault L3	l	–	
yellow 8	Zero Power forward	l	Short Circuit forward	l
yellow 9	Zero Power reverse	u	Short Circuit reverse	l

- TRIP-command

Several logs with a total of 12 s are possible. The disturbance data logging caused by an input signal is always continuous during the active signal, max. 4 s.

The stored disturbance data can only be visualised on a PC screen using PC operating programs.

The installed back-up battery preserves the content of the disturbance data memory if the supply voltage fails.

### 7.5 Fault localisation

Following a final trip command, the fault will be localised. The indication is provided in kilometres (km), in percentage (%) of line length and as a primary reactance in ohms ( $\Omega$ ).

### 7.6 Measured-value checking

Measured current and voltage values arriving through the protector transformers are monitored for plausibility. This includes, among others, phase sequence and balancing checks during the non-started state of the DSRZW 2.

If a voltage path disturbance appears, the non-directional overcurrent-time protection is used.

## 8 Tests

### 8.1 C.B.-Test, Test auto-reclosing

To test the break and make circuits of the circuit breaker, an auto-reclosing test operation may be performed. This function is available after pressing the "Tests" key on the DSRZW 2 or by applying a special input signal. If an auto-reclosure is impossible, this function may work as trip test.

### 8.2 Self-test

Comprehensive monitoring routines of the hardware and for the software are provided to detect and signal malfunctions of the protector. There are cyclic tests and tests during start-up.

Depending on the detected abnormal condition, the protector is taken out of operation or an alarm is issued. Using the green LED to indicate the ready state and the red LED for malfunction and alarm signal is advisable. The pre-configured signal relay "Protection available" signals any malfunction and lack of auxiliary voltage. Alarms may be configured to another signal relay.

### 8.3 Application of test plug devices

Checking the mounted protection relays periodically many power supply companies apply test plug devices or test selector switches that cause a safe switch over from the measured quantities of the system to the test devices. The

<sup>\*)</sup> DSRZW 2 has to be supplied



TRIP command to the circuit breaker is also involved into the switch over.

Building the "check/test mode", the test plug device respectively the test selector switch has to make a binary signal for one optocoupler input of the protector available. This marks all logged events as "test".

## 9 Serial interfaces

The front 9-pole Sub-D connector constitutes the interface S0 for the operator PC.

## 10 Operation

### 10.1 Front panel

The following operations can be executed on the front panel:

- Reading and resetting of LED's and display provided automatically by the relay including the following:
  - operating value display during normal operation,
  - LCD report after a TRIP command of the protector,
  - LCD report after switching off the protector and because of an internal malfunction.
  - In case of an alarm, the operating values and the alarms are displayed.
- Setting of the protector  
Pressing the password-protected "Setting" key displays an easily comprehensible plain-text menu comprising the following main items:
  - *Equipment adaptation* - data concerning the installation and the system,
  - *Protective functions* – switching the protective and additional functions on or off,
  - *Input configuration* - free assignment and logic combination of optocoupler input signals to device software functions.
  - *Output configuration of relays and LED's* - free assignment of the possible output commands to trip relays, signal relays and LED's, this can generate group signals,
  - *Characteristic sets* - setting values for the selected protective functions are separately adjustable for two characteristic sets,
  - *Device address*,
  - *Operator control* - common settings, e.g. protector On/Off, password, date and time, operating mode, etc.

- Display of stored information  
After pressing the "Readout" key the stored information may be indicated on the display:
  - logged events (with running time),
  - all settings,
  - information on the protector type, e.g. versions.
  - if the DSRZW 2 is not powered the last LED's state can be seen for a short time.As the key is not password-protected and the information selection is shown in a plain-text menu, it is easy to get a local readout.

- Calling of tests  
Pressing the "Tests" key accesses a menu used for the above-mentioned tests and the manufacturer's service. The menu is password-protected.

### 10.2 PC operator routine COMM-3 <sup>\*)</sup>

Although no PC software is necessary for setting and readout of the protection device a PC operator routine COMM-3 and graphic software SDA 2 is available. It is used for preparing and performing the setting of the digital protection relay at the engineer's place of work. In addition to setting the protectors, the routine may also be used for reading out and displaying events and with the additionally graphics software SDA 2 disturbance data can be displayed. Archiving of settings and events is easy to do.

Graphic display and evaluation of disturbance data are by the graphics software featuring the COMTRADE file format (IEEE standard C37.1991). Using this file format data exchange may be performed between compatible devices such as state of the art test devices.

<sup>\*)</sup> DSRZW 2 has to be supplied



## 11 Specifications

The protection relay satisfies the requirements of the product standards EN 60255-6 (IEC 255-6); DIN 57 435, part 303; IEC 255-3; IEC 255-12.

### Mechanical construction

- sheet-steel housing (depending on design) for panel surface mounting or panel flush mounting
- weight approx. 9 kg
- degree of protection (EN 60529)
 

housing	IP 51
terminals	IP 20
- terminals
 

transformers solid wire	0.5 ... 16 mm <sup>2</sup>
stranded wire	0.5 ... 10 mm <sup>2</sup>
others: solid wire	0.2 ... 4 mm <sup>2</sup>
stranded wire	0.2 ... 2.5 mm <sup>2</sup>

### Permissible ambient conditions

- operating temperature -10°C...+55°C
- storage temperature -25°C...+55°C
- transport temperature -25°C...+70°C
- humidity rating, yearly mean value 75% for 30 days <95% and 40°C moisture condensation not permitted

### Mechanical strength

- resistance to earthquakes (IEC 255-21-3)
 

nominal frequency range	1...35 Hz
cut-off frequency	8...9 Hz
horizontal	3.5 mm; 10 m/s <sup>2</sup>
vertical	1.5 mm; 5 m/s <sup>2</sup>
- vibration strain (IEC 255-21-1, IEC 68-2-6)
 

Fc: 10...150 Hz; 0.075 mm; 1g
-------------------------------
- repeated impact strain
 

Ea: 11 ms; 15 g
(IEC 255-21-2) Eb: 16 ms; 10 g

### Auxiliary power supply

- Instrument transformer power supply
- current transformer 4
 

minimum current for supply when fed through (x=1;2;3 y=2;3;1)	
Lx + Ly - transformer	0.5·In
Lx + N - transformer	0.33·In
(Lx-transformer only)	1·In
- average rated consumption
 

Lx-transformer	<17 VA
N-transformer	<30 VA
- load capability
 

permanent, N transformer	1·In
1 s, N transformer	40·In
limiting dynamic value (10 ms), N transformer	100·In
- voltage transformer 1
 

input voltage, switchable	100/110 V, 50 Hz
or	230 V, 50 Hz
average rated consumption	<15 VA
- battery for internal data backup in case of auxiliary power failure
 

3 V CR ½ AA lithium
---------------------

### Measuring input circuits

- nominal frequency 50 Hz
- current paths
 

rated current (In), design-dependent	1 A or 5 A
--------------------------------------	------------

- load capability (N-transformer usable for power supply only see above)
 

permanent	2·In
1 s	80·In
limiting dynamic value (10 ms)	200·In
- voltage paths
 

nominal voltage (Vn)	100 V
load capability	1.5·Vn
power consumption at Vn (measuring circuit only)	< 0.3 VA

### Binary signal inputs (optocoupler) <sup>1</sup>

- nominal input voltage (Vi) 24...220 V DC
- power consumption < 4·10<sup>-4</sup> (Vi)<sup>2</sup> W
- logic low level <10 V

### Output relays

- trip relays (marked S1, S2)
 

switching voltage	300 V DC, 250 V AC
limiting making capacity	1250 W (VA)
limiting breaking capacity	
50...250 W (voltage- and load dependent)	
0.3 A at 220 V DC, L/R = 0 ms	
0.15 A at 220 V DC, L/R = 40 ms	
both contacts in series:	
0.25 A at 220 V DC, L/R = 40 ms	
- S1: limiting continuous current
 

1x8 A or 2x5 A /40°C
----------------------
- S2: limiting continuous current 8 A
 

limiting short-time current for 0.5 s	30 A
---------------------------------------	------
- signal relays (marked M1, M2)
 

switching voltage	300 V DC, 250 V AC
switching current	8 A
switching capacity	<2000 VA,
50...220 W (voltage-dependent)	
limiting continuous current	6 A

### Serial interface

- PC interface RS 232; 9-pin Sub-D

### Displays

- LED's green: 1; red: 1; yellow: 10
- LCD four-line of 20 characters each

### Setting values and ranges (selection)

- overcurrent stage I<sub>L></sub> 0.20...2.0 (...5)·In
- high current stage I<sub>L>></sub>, definite-time
 

2.0...40.0·In	
I <sub>L&gt;&gt;</sub> , inverse-time	0.5...10.0·In
- earth-fault current stage I<sub>E></sub> 0.1...2.0·In
- resetting ratio I<sub>L></sub> 0.95 (fixed)
 

I <sub>L&gt;&gt;</sub> , I <sub>E&gt;</sub>	0.20...0.95
---	-------------
- definite-time time stages for forward and reverse direction
 

0.00...9.99 s
---------------
- inverse-time time stages, time factor t<sub>></sub>, t<sub>E</sub>

for forward direction	0.05...2.00 s
reverse direction	0.2...8.00 s
maximum operate time, t <sub>amax</sub>	10...60 s
- direction decision internal angle 15...75 °
- auto-recloser
 

short open time	0.05...9.99 s
long open time	1...300 s
action time window	0.05...9.99 s
reclaim and blocking time	1...300 s

- fault locator
 

secondary reactance	0.05...150 Ω
---------------------	--------------
- pulse shaper stage
 

on and off delay	0...9.99 s
------------------	------------

### Routine testing

- dielectrics test 2.5 kV, 50 Hz, 1 s
- Each protection relay will be subjected to a 72-hour alternate temperature test while in function.

### Type testing

- impulse voltage test
 

5 kV; 1.2/50 μs; 500 Ω
------------------------
- dielectrics test 2.5 kV, 50 Hz, 60 s
- EMC noise immunity EN 50082-2, severity class 3
 

electromagnetic RF field	
magnetic field of power engineering frequency	
discharge of static electricity (ESD)	
fast transients (bursts)	
transients (surges)	
RF interference test (IEC 255-22-1)	
transformer cross voltage	2.5 kV
- EMC emitted interference EN 50081-2 -B

<sup>1</sup> On special-wish, differently from the default long-range input voltage optocoupler inputs can be dimensioned for a Low/High switching voltage of about 60 V.



Order data DSRZW 2

PI.-No.: 1743 1-3 --0  
 rated current: 6<sup>th</sup> digit  
 1 A 1  
 5 A 5  
 type of housing: 8<sup>th</sup> digit  
 panel surface-mounted  
 CT terminals down 0  
 CT terminals right 2  
 CT terminals left 4  
 panel flush-mounted  
 CT terminals down 1  
 CT terminals right 3  
 CT terminals left 5  
 language: 9<sup>th</sup> digit  
 German 0  
 English 1

design includes:	
binary inputs	2
trip relays	2
signal relays (1 changeover)	2
AR	X
Pulse shaper stage	X

The desired input-voltage

- 230 V AC or
- 100/110 V AC

of the voltage transformer in the supply has to be stated. Without this information the factory adjustment is 230 V AC.

Optocoupler inputs:

On special-wish, differently from the default long-range input voltage optocoupler inputs can be delivered with a Low/High switching voltage of about 60 V. This wish is separated with order to declare.

Heed please that when using two-wire signal loop two optocoupler-inputs are connected in series. Therefore, only the half of the auxiliary voltage is available at an input.

Accessories

PC-protector interconnecting cable  
 PI. No.: 1743 900 010

COMM-3 PC operator software

• Management program  
 PI.-No.: 1744 990 00-  
 Variant: 10<sup>th</sup> digit  
 Full-version 0  
 Upgrade from COMM-2 to 3 1  
 Update of COMM-3 2  
 Demo version 9  
 On supplied CDROM the user manual exists as a PDF-file.

• Device programs

PI.-No.: 1744 991 --  
 Type of device: 8<sup>th</sup> and 9<sup>th</sup> digit  
 all devices [structure versions] 00  
 DM 2 [1004] 10  
 DSRZ(W) 2 [2001] 20  
 DSZ(W) 2 [3007] 30  
 DSZW 4 [3105] 31  
 DSZ 4 [3205] 32  
 DQ2S 2, DQ3S 2 [4008] 40  
 DD 2 [5033] 50  
 P9x-DD.. 6 [5601] 56  
 DDS(E) 2 [6002] 60  
 DSRZE 2 [7000] 70  
 P9x-DS.. 6 [7604] 76  
 Variant: 10<sup>th</sup> digit  
 current structure version 0  
 old structure version 1

When reordering a device program the structure version number of the device is necessary additionally (see label on device). Example for DSZ 2, old structure version 3001:

PI.-No. 1744 991 301- 3001

SDA 2 graphics software

PI.-No.: 1744 992 000  
 On supplied CDROM the user manual exists as a PDF-file.

User manual COMM-3, SDA 2 printed version

PI.-No.: 1744 993 0--  
 Language: 9<sup>th</sup> digit  
 German 0  
 English 1  
 Manual: 10<sup>th</sup> digit  
 COMM-3 0  
 SDA 2 1

Capacitor release device KA 4

PI.-No.: 1737 010 -00  
 Variant  
 a) 230V U<sub>in</sub> / 300V U<sub>o</sub> 0  
 b) 100/110V U<sub>in</sub> / 300V U<sub>o</sub> 1  
 c) 100/110V U<sub>in</sub> / 130V U<sub>o</sub> 2  
 d) 100/110V U<sub>in</sub>, 50mA I<sub>in</sub> / 130V U<sub>o</sub> 3  
 e) 100/110V U<sub>in</sub> / 130V U<sub>o</sub>, 7200µF 4  
 with U<sub>in</sub> input a.c. voltage  
 I<sub>in</sub> input current  
 U<sub>o</sub> output d.c. voltage

Sprecher Automation  
 Deutschland GmbH  
 Moellendorffstr. 47  
 10367 Berlin  
 Germany  
 Tel: +49 30 6449241-70  
 Fax: +49 30 6449241-99  
 Email: [info@sprecher-automation.com](mailto:info@sprecher-automation.com)  
 Internet: [www.sprecher-automation.de](http://www.sprecher-automation.de)

Sprecher Automation GmbH  
 Franckstrasse 51  
 4018 Linz  
 Austria  
 Tel: +43 732 6908-0  
 Fax: +43 732 6908-321

Sprecher Automation GmbH  
 Ignaz-Koeck-Straße 10  
 1210 Wien  
 Austria  
 Tel: +43 732 6908-601  
 Fax: +43 732 6908-5601

Sprecher Automation  
 Polska Sp z o.o.  
 ul. Łączna 4  
 58-100 Świdnica  
 Poland  
 Tel: +48 74 85135-31  
 Fax: +48 74 85135-32

Sprecher Automation  
 spol. s r.o.  
 Kopčianska 14  
 851-01 Bratislava  
 Slovakia  
 Tel: +421 2 682055-00  
 Fax: +421 2 682055-10

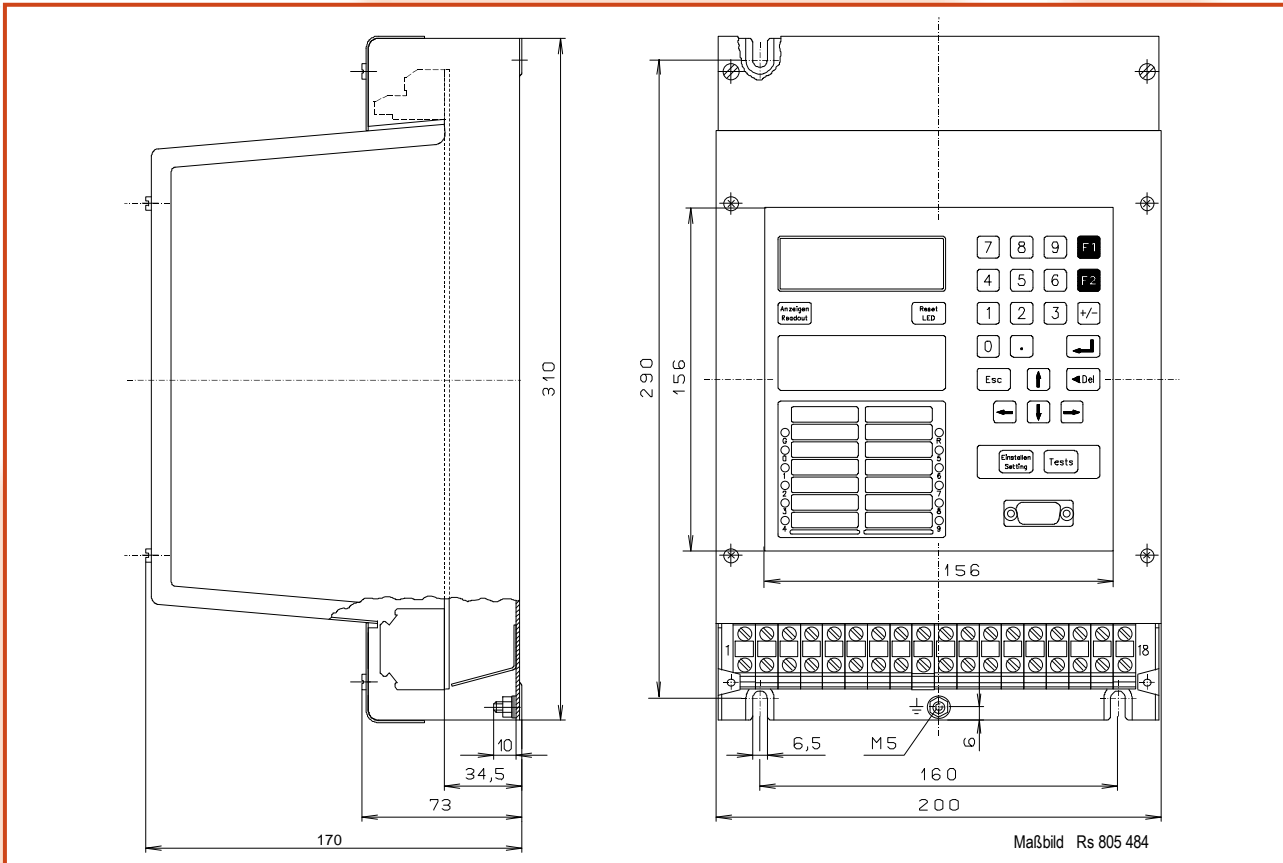

Fig. 9: DSRZW 2 housing for panel surface mounting, lower terminal cover not shown in top view. With the horizontal models the keypad is turned + or -90°.

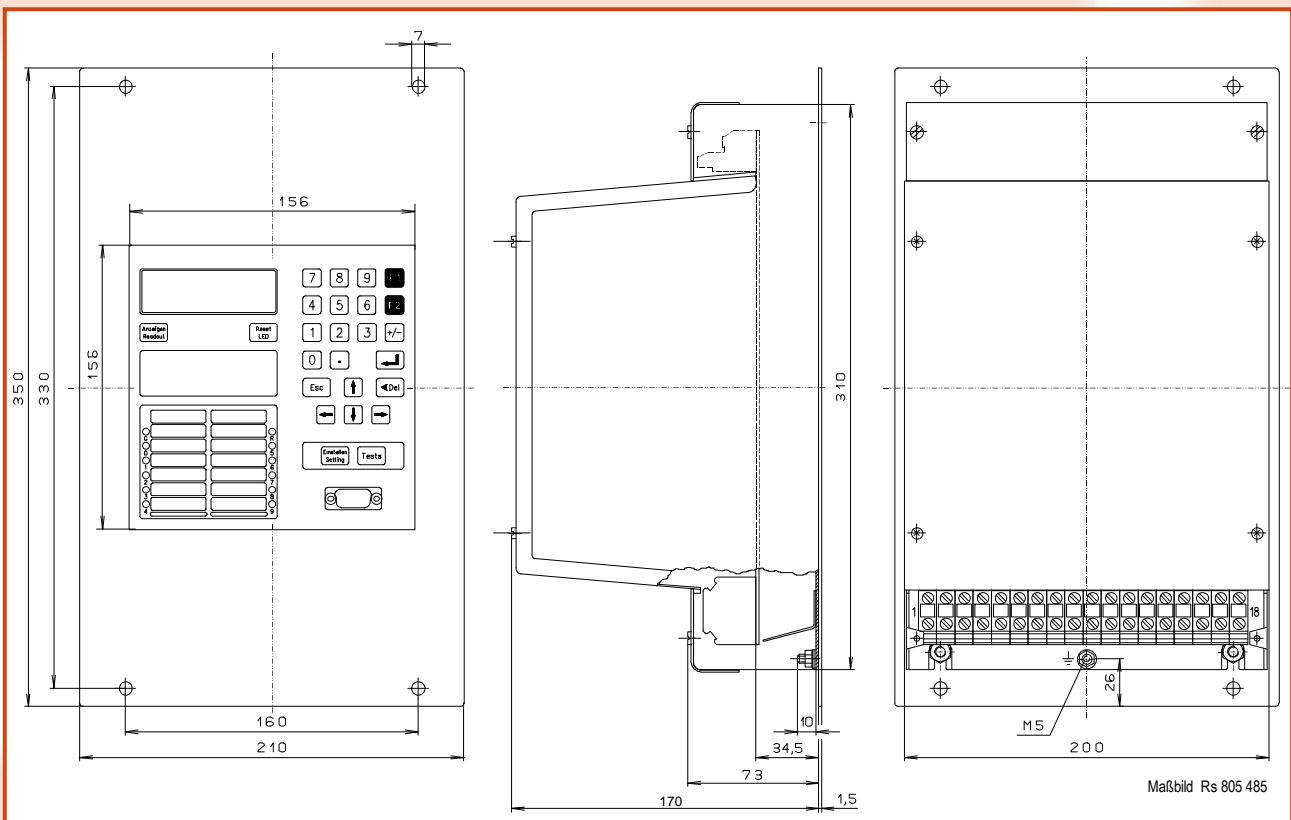

Fig. 10: DSRZW 2 housing for panel flush mounting, lower terminal cover not shown in rear view (right-hand side). The panel cut-out should be 202 mm \* 312 mm when device will be put through from front side. With the horizontal models the keypad is turned + or -90°.

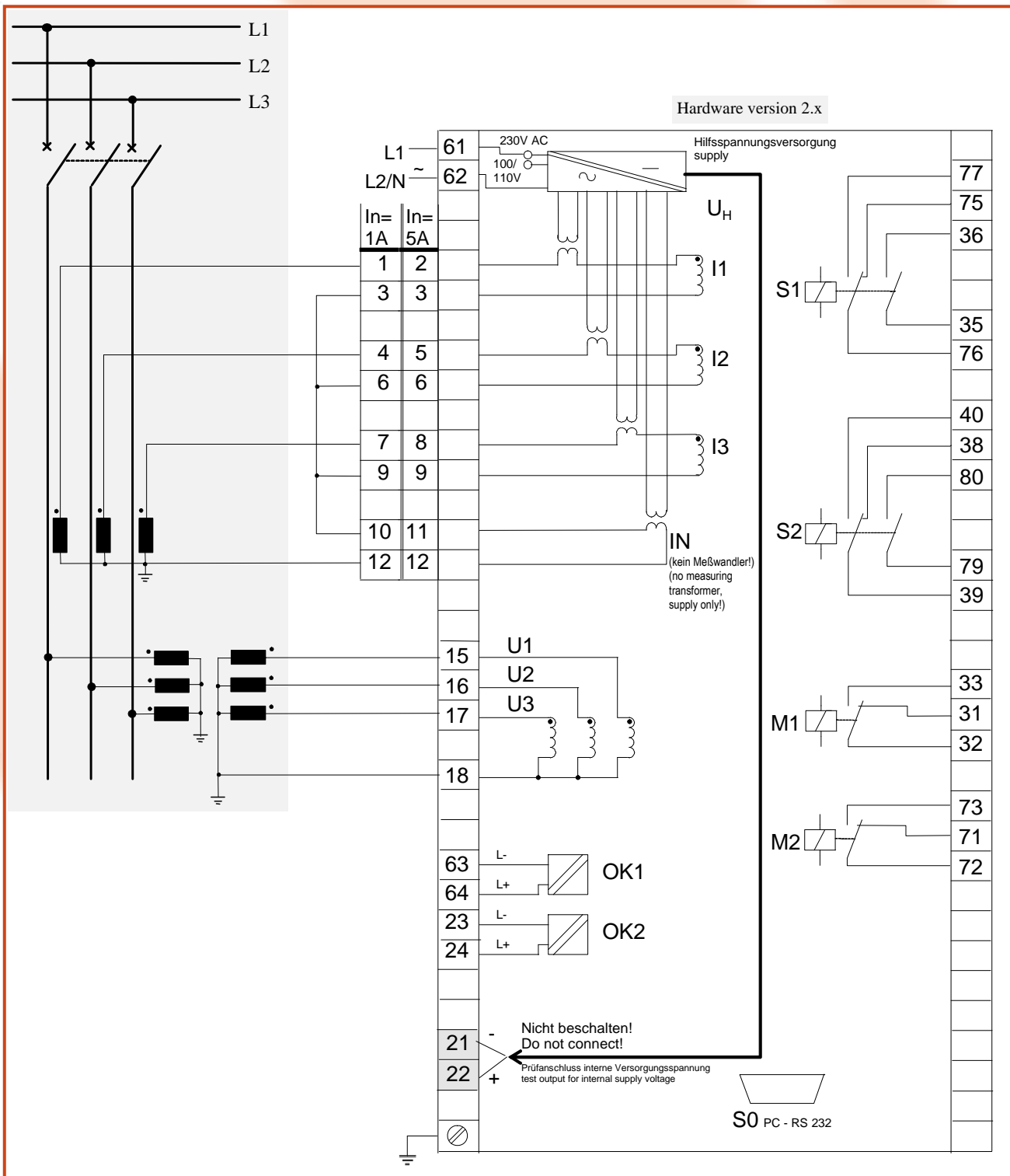

Fig. 11: Terminal assignment of DSRZW 2 for rated currents of 1 A respectively 5 A depending on design

© Sprecher Automation 2009 - A liability regarding the correctness and completeness of information (specifications) in the brochure is excluded. Any statements (specifications) as well as the termination of the production of a certain model are without prior notice subject to modifications. The specifications of a model may vary from country to country.